

75cm Series 9 2 Burner Gas Cooktop, Natural Gas

Contemporary



Choose this wide two-burner to suit your kitchen layout, and enjoy the flexibility of dual flame wok burners.

- A wide cooking area with two wok burners to support large cookware
- A flame-failure safety device; if the flame goes out, the gas turns off

DIMENSIONS

Height	59 mm
Width	750 mm

Depth

450 mm

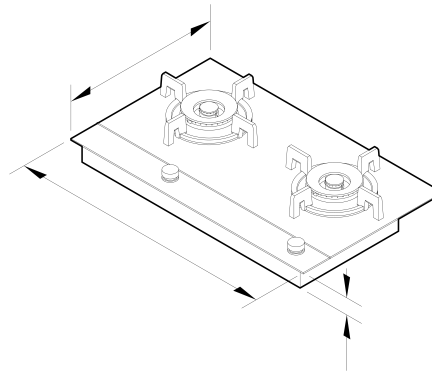

FEATURES & BENEFITS

Beautiful burners

Our award-winning Gas on Glass Cooktops deliver total cooking precision with the latest burner technology. The consistent flame and heat distribution of the dual flame wok burner combined with highly responsive dials offer precise heat control.

Complementary design

The black reflective glass, brushed stainless steel and polished metal trim blend elegance with durability. Designed to match the Fisher & Paykel family of appliances.

Precise Control

Simply turn the dials to ignite the flame quickly and safely. Precise heat adjustment from very high to very low heat can perfect a slow simmer for sauces or an intense heat for searing steaks.

Safe And Sound

The flame failure safety device automatically turns off the gas if the flame is accidentally extinguished. Eco-friendly ceramic glass, without arsenic or heavy metals, is used in the manufacturing process.

Easy Cleaning

Life is made a little easier with this easy to clean glass cooktop. The design allows you to simply remove the trivets, wipe down the glass and walk away.

Handy Accessories

This cooktop comes with a small pot support and wok stand to complement different cooking styles.

SPECIFICATIONS

Accessories (included)

Small pan support	•
Wok stand	true

Burner ratings

Wok burner power	4.5kW
------------------	-------

Burners

Number of burners	2
-------------------	---

Cleaning

- Easy clean cooktop design
- Quick component removal

Consumption

Energy rating	Grade 2
Heating efficiency	59%

Controls

- Dual wok control
- Toughened fused glass graphics
- Turned stainless dials

Performance

- Cast iron trivets
- Electronic ignition
- Quick connect gas valves

Power requirements

Supply voltage	230-240 V
----------------	------------------

Product dimensions

Depth	450 mm
Height	59 mm
Width	750 mm

Safety

- Flame failure system

Zones

Number of zones	2
-----------------	----------

SKU	81421
-----	--------------

The product dimensions and specifications in this page apply to the specific product and model. Under our policy of continuous improvement, these dimensions and specifications may change at any time. You should therefore check with Fisher & Paykel's Customer Care Centre to ensure this page correctly describes the model currently available. © Fisher & Paykel Appliances Ltd 2020

Other product downloads available at fisherpaykel.com

- [↓](#) DWG
- [↓](#) Installation Guide - Joining Strip (English)
- [↓](#) Installation Guide (Chinese)
- [↓](#) Restriction of the Use of Hazardous Substances (Chinese)
- [↓](#) User Guide (Chinese)

Where applicable:

All appliances use energy, and energy usage typically generates carbon emissions. **Fisher & Paykel Appliances' In-use Energy Carbon Emissions Estimate** indicates carbon emissions from a product's in-use energy. This is calculated either annually or per cycle, using the product's market-specific energy label energy consumption data multiplied by the carbon emissions factor for energy in your country or region.

Our In-use Energy Carbon Emissions Estimate is designed to assist customers in making informed purchasing decisions when comparing different Fisher & Paykel products. For example, a heat pump dryer typically has a lower In-use Energy Carbon Emissions Estimate than a vented dryer.